

OUR UNRIVALED PRODUCT WARRANTY

Standard Warranty

(applies only to product(s) delivered within the United States and Canada)

All HindlePower charger products are warranted to be free from defects in material and workmanship for a period of five (5) years from date of manufacture. During the term of the warranty period: parts, assemblies, or components deemed to be defective will be repaired or replaced at our option, free of charge. All costs related to removal, reinstallation and transportation will be paid by the purchaser/customer and/or operator of the product. Evaluation, repair and/or replacement of any defective part(s) are FOB manufacturer's factory.

This warranty does not cover products or parts that are damaged from improper use or abuse, as determined by HindlePower. Accessory items or additional items carry only their respective manufacturer's warranty. Consumable items (such as fuses and electrolytic capacitors), which wear out under normal use are specifically not covered by this standard warranty. Any consequential damage due to diagnosis or repair by any party other than HindlePower authorized personnel is not covered under this warranty.

NOTE: Requests for returns or claims must be submitted to our Factory Service Center for Return Material Authorization(RMA) instructions and assignment. Returns that do not follow this procedure will not be honored.



Other Products Available from HindlePower:

AT30 Microprocessor Battery Charger	JF5018	UMC Universal Maintenance Charger	JF5008
AT Series Options & Accessories	JF5020	Single Cell Charger	JF5007
AT Series Communications Module	JF5014	Mobile DC Power System	JF5041
AT-DC Series Distribution Panel	JF5032	The EPIC Series Console	JF5043
SCR/SCRF Series Utility Battery Charger	JF5010	Best Battery Selector	JF5048



**Mobile DC
Power System**

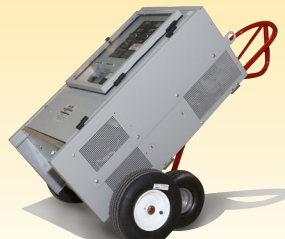

**Universal
Maintenance Charger**



**AT30 Microprocessor
Battery Charger**



**The EPIC
Series Console**

AT10.1 SERIES

Microprocessor Controlled Float Battery Charger



**Looking for the world's premium
microprocessor controlled float battery charger?**

The AT10.1 is the world's easiest to operate float battery charger. It has over 20 years of proven reliability and has become the industry's "gold standard" for all stationary battery charging applications. We are so confident in our product that we have backed the AT10.1 with our unrivaled 5 Year Standard Warranty.



← SCAN WITH YOUR SMART PHONE
FOR HINDLEPOWERINC.COM



CSA C22.2 · NRTL/C · UL 1012/UL 1564 compliant
Seismic qualified
ABS · CE certification available upon request

JF5006

HINDLEPOWER
Quality & Integrity - Our Passion



HINDLEPOWER

Quality & Integrity - Our Passion

What is the AT10.1?

Combining the performance and accuracy of a microprocessor with the reliability of SCR power conversion technology makes the AT10.1 Series the standard in stationary battery chargers. AT10.1s are easy to install, operate and maintain. The AT10.1 is packed with the most standard features and best warranty in the industry.

What are the most common applications for the AT10.1?

Utility & Communications

Power Generation
Substations
Microwave Relay Sites
Switchgear



Manufacturing

Emergency DC Power
DC Operated Breakers
Alarm Systems

Commercial

Alarm Systems
Uninterrupted Power Systems
DC Control Systems

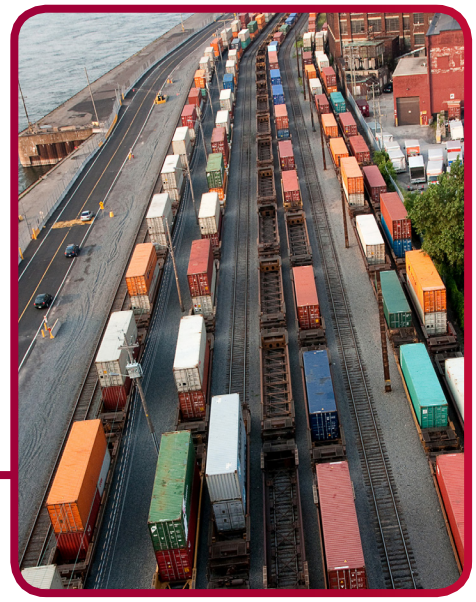

Transportation

Signal Systems
Switchgear
Alarm Systems

SPECIFICATIONS & STANDARD FEATURES

SPECIFICATIONS

AC Input

- **Group 1 (6-25 Adc) Voltage:**
120/208/240Vac (multi-tap) 60Hz
480Vac 60Hz
220Vac, 380/416Vac 50/60Hz
550-600 Vac 50/60Hz
- **Group 2 (30-100 Adc) Voltage:**
120, 208, 240 or 480Vac 60Hz
220Vac, 380 or 416Vac 50/60Hz
550-600 Vac 60Hz
- **Input Voltage Tolerance:**
+10%, -12%
- **Input Frequency Tolerance:**
±5%
- **Efficiency:**
85-90% typical for 130Vdc at 50-100% load

DC Output

- **Voltage Ratings:**
12, 24, 48, or 130Vdc nominal
- **Current Ratings:**
GROUP 1: 6, 12, 16, 20, 25Adc
GROUP 2: 30, 40, 50, 75, 100Adc
- **Continuous Rating:**
110% rated current at maximum equalize voltage at 50°C
- **Current Limit Adjustment Range:**
50% to 110% rated output
- **Voltage Regulation:**
±0.25% for line, load and temp. variations
**Regulation at max. equalize voltages may not meet ±0.25%*
- **Electrical Noise:**
32dBrc
- **Ripple:**
12/24/48Vdc
 - Unfiltered on battery 1% Vrms
 - Filtered on battery 30mVrms
 - Filtered off battery 1% Vrms
 - Battery Eliminator 30mVrms130Vdc
 - Unfiltered on battery 2% Vrms
 - Filtered on battery 100mVrms
 - Filtered off battery 2% Vrms
 - Battery Eliminator 100mVrms
- **Surge Withstand Capability:**
Meets IEEE-472, ANSI C37.90a

Safety and Acceptance

- Meets NEMA PE 5-1996, PE 5-1997(R2003) specification
- NEMA-1/IP20 type standard enclosure
- Third party agency approvals:
 - CSA C22.2 compliant
 - - NRTL/C · UL 1012/UL 1564 compliant
 - Seismic qualified
 - ABS or CE certification available upon request.
- Made in the United States of America 



Environmental

- Operating Ambient Temperature 0°F to 122°F (-18°C to 50°C) w/o derating
- Operating Altitude 10,000 feet (3,000 meters) above sea level w/o derating
- Relative Humidity 0% to 95% (without condensation)
- Audible Noise Less than 65 dBA at any point 5ft (1.5m) from any vertical surface of enclosure

STANDARD FEATURES

- 5 Year Product Warranty
- Universal main control board operates in any AT Series charger
- Alarm assembly with local LEDs and summary relay contact for AC Failure, DC Failure, High Vdc, Low Vdc, Positive(+) and Negative(-) ground fault
- High DC voltage shutdown
- Forced load share during parallel operation
- Float/equalize selector switch with indicating lights
- Manual equalize timer (0-255 hr.) with indicating lights
- AC line failure automatic equalize timer (0-255 hr.) with indicating light
- AC On indicating light
- 1% Digital LED meter for Vdc, Adc, timer hours and alarm settings
- AC input and DC output circuit breakers
- Membrane front panel
- Front panel controls can be disabled for security
- A redundant analog circuit for LVDC alarm, independent of the microprocessor
- Redundant control loops for higher reliability
- Local or remote voltage sense with redundancy to protect against remote sense failure
- Self-diagnostics
- Input & output MOV surge suppressors
- Reverse polarity protection via free wheeling diodes
- CU-AL I/O compression lugs
- Switchboard wire, UL VW-1
- Enclosure pre-treated using a 5-stage iron phosphate process with baked epoxy powder coating in ANSI 61 gray

CUSTOMIZE YOUR AT10.1

OPTIONS THAT LET YOU DESIGN YOUR CHARGER EXACTLY HOW YOU NEED IT!

SUMMARY OF OPTIONS

- DC output filtering: per NEMA PE5 1996, standard and battery eliminator
- Medium & High AIC Breakers
- Auxiliary alarm relay board
- Copper ground bus
- AC lightning arrestor
- Fungus proofing (tropicalization)
- Static proofing
- Communications module: DNP3 Level 2 or MODBUS protocols
- Battery temperature compensation
- Fan control contactor
- Custom Paint
- NEMA 4 (12) type enclosure w/fan
- Rack mounting
- Wall mounting
- Floor mounting stand
- NEMA Type 2 Drip Shield
- Barrier type alarm terminal block
- Forced load share cable
- End of discharge alarm
- Battery discharge alarm
- Zero-center ground detection meter
- Analog AC voltmeter
- Analog AC ammeter
- Cabinet heater assembly
- CE marking upon request
- ABS certification upon request
- Custom drawing package w/ optional CAD and PDF files
- Mechanical lock for front door

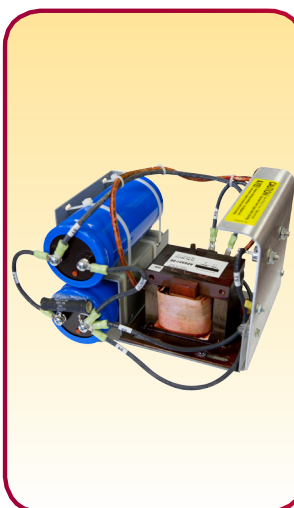

Filtering STANDARD

Output filtering is essential whenever there is need for low ac ripple and low noise on the dc bus for critical loads. The standard dc output filtering limits ripple to no more than 30mV RMS on 12, 24 & 48Vdc units, and 100mV RMS on 130Vdc units, measured at the battery terminals. This feature meets the specifications of NEMA standard PE5-1996, and is recommended for installations using VRLA or gelled electrolyte batteries.

BATTERY ELIMINATOR

An additional "battery eliminator" feature is also available, meeting the specifications of NEMA standard PE5-1996 with no battery connected, measured at the dc output terminals. This feature is recommended for sites where the battery may occasionally be disconnected from the dc bus for maintenance. Additional filtering is essential to limit ac ripple and noise for critical dc loads.

ORDERING	
FACTORY INSTALLATION YES	Factory Installation use Specification Tables on pages 10 & 11
AVAILABLE FOR FIELD INSTALLATION YES	Field Installation use Part Number Group 1: <i>EJ1072-9#</i> Group 2: <i>EJ5023-9#</i> <i>Contact manufacturer for specific part number.</i>



Medium & High AIC Breaker

This feature provides thermal-magnetic circuit breakers with higher Ampere Interrupting Capacity ratings than the standard. See the tables on Page 10 and 11 for Group 1 and Group 2 medium and high AIC breaker ratings. For AT10.1 Group 1, ac and dc breakers ratings must be ordered together, and are supplied in a separate penthouse enclosure. For Group 2, ac and dc breakers can be specified separately and are supplied in the standard cabinet.

ORDERING	
FACTORY INSTALLATION YES	Factory Installation use Specification Tables on pages 10 & 11
AVAILABLE FOR FIELD INSTALLATION NO	NOT AVAILABLE FOR FIELD INSTALLATION

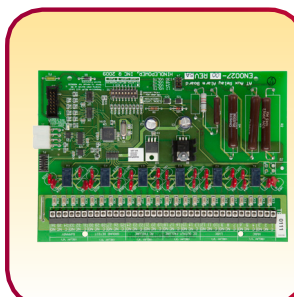

Auxiliary Alarm Relay Board

The AT10.1 features several industry-standard alarms, with individual LED indicators on the front instrument panel, and are accessible to the user via one (1) Summary Alarm contact on the Main Control PC Board. This feature provides a separate user-accessed pc board, featuring discreet two (2) form-C relay contacts for all six (6) alarms. In AT10.1 Group 1 ratings, the board is supplied in an additional penthouse enclosure. In AT10.1 Group 2 ratings, it is supplied within the standard enclosure.

ORDERING	
FACTORY INSTALLATION YES	Factory Installation use Specification Tables on pages 10 & 11
AVAILABLE FOR FIELD INSTALLATION YES	Field Installation use Part Number GROUP 1: <i>EI0213-0#</i> <i>Contact manufacturer for specific part number.</i> GROUP 2: <i>EI0213-02</i>

CUSTOMIZE YOUR AT10.1

OPTIONS THAT LET YOU DESIGN YOUR CHARGER EXACTLY HOW YOU NEED IT!

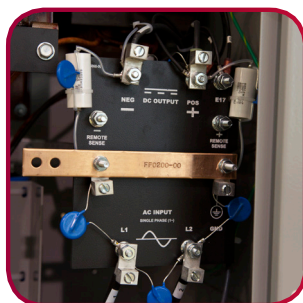

Copper Ground Bus

This option provides a convenient means to tie the AT10.1 to the site building ground. A copper ground bus bar is provided at the I/O terminal, with an extra CU-AL compression box lug.

FACTORY
INSTALLATION

YES

AVAILABLE FOR
FIELD INSTALLATION

YES

ORDERING

Factory Installation use
Specification Tables on
pages 10 & 11

Field Installation use Part Number
GROUP 1: *EI0195-00*
GROUP 2: *EI0195-02*



AC Lightning Arrestor

This options features an industrial-grade surge arrestor in polycarbonate housing, rated for 20,000 Amperes. It is recommended for installations with risk of frequent ac surges, such as high elevations or severe weather.

FACTORY
INSTALLATION

YES

AVAILABLE FOR
FIELD INSTALLATION

YES

ORDERING

Factory Installation use
Specification Tables on
pages 10 & 11

Field Installation use Part Number
GROUP 1: *EJ1074-00*
GROUP 2: *EJ1074-01*



Fungus Proofing

This treatment is also referred to as "tropicalization". It coats electrical components and internal wiring connections with a fungus-resistant, non-conductive film (approx. 1 mil thickness). User termination points are not coated, nor are relay contacts, and any electrical connectors where the spray would interfere with functionality. The application is fully cured at time of shipment.

FACTORY
INSTALLATION

YES

AVAILABLE FOR
FIELD INSTALLATION

NO

ORDERING

Factory Installation use
Specification Tables on
pages 10 & 11

NOT AVAILABLE FOR
FIELD INSTALLATION



Static Proofing

Used in "arid" environments, this treatment coats electrical components and connections with a static-resistant, non-conductive film (approx. 1 mil thickness). User termination points are not coated, nor are relay contacts, and any electrical connectors where the spray would interfere with functionality. The application is fully cured at time of shipment.

FACTORY
INSTALLATION

YES

AVAILABLE FOR
FIELD INSTALLATION

NO

ORDERING

Factory Installation use
Specification Tables on
pages 10 & 11

NOT AVAILABLE FOR
FIELD INSTALLATION

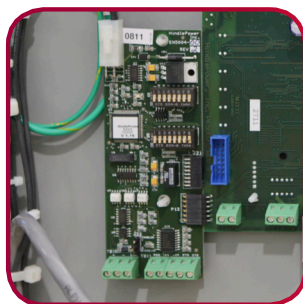

Communications

This option allows full remote monitoring of the AT10.1 and control of the front panel features, using MODBUS or DNP3 Level 2 protocols. Standard serial connections are provided for use with local SCADA systems.

Additional Ethernet and Fiber Optics Modem interfaces are also available for use with the AT Communications option. Contact factory for part number.

FACTORY
INSTALLATION

YES

AVAILABLE FOR
FIELD INSTALLATION

YES

ORDERING

Factory Installation use
Part Number when ordering
12Vdc: *EJ5037-01*
24Vdc: *EJ5037-02*
48Vdc: *EJ5037-03*
130Vdc: *EJ5037-04*

Field Installation use Part Number
12Vdc: *EJ5037-11*
24Vdc: *EJ5037-12*
48Vdc: *EJ5037-13*
130Vdc: *EJ5037-14*

CUSTOMIZE YOUR AT10.1

OPTIONS THAT LET YOU DESIGN YOUR CHARGER EXACTLY HOW YOU NEED IT!

	<h3>Temperature Compensation</h3> <p>Supplied in a kit, this option adjusts the AT10.1 dc output voltage up or down, in response to battery temperature fluctuations. Temperature is measured by an epoxy-enclosed thermistor. This probe is mounted on or near the battery, and connected by a cable to the Main Control PC Board. It is compatible with both lead-acid and nickel-cadmium batteries, and recommended for VRLA batteries. Cable lengths of 25, 50, 100, and 200 ft are available.</p>	FACTORY INSTALLATION NO	ORDERING CAN BE ORDERED WITH CHARGER BUT MUST BE FIELD INSTALLED
		AVAILABLE FOR FIELD INSTALLATION YES	Field Installation use Part Number 25ft: <i>EJ5033-00</i> 50ft: <i>EJ5033-01</i> 100ft: <i>EJ5033-02</i> 200ft: <i>EJ5033-03</i>

	<h3>Barrier Type Alarm Terminal Block</h3> <p>This option features a separate molded phenolic terminal block, wired directly to the Auxiliary Alarm Relay PC Board. It allows the user to connect remote alarm wiring with ring or fork type lugs. The terminals are rated for 20A at 150 Vac/Vdc, and accept wire sizes #16 to #14 AWG.</p>	FACTORY INSTALLATION YES	ORDERING Factory Installation use Part Number when ordering 1 FORM C: <i>EJ5130-01</i> 2 FORM C: <i>EJ5130-02</i>
		AVAILABLE FOR FIELD INSTALLATION YES	Field Installation use Part Number 1 FORM C: <i>EJ5130-01</i> 2 FORM C: <i>EJ5130-02</i>

	<h3>Mechanical Lock For Front Door</h3> <p>The AT10.1 front panel controls can be disabled by setting a jumper on the back of the Main Control PC board. For installations where extra security is required, the front instrument panel, or door, can be physically locked closed. This option provides a locking provision on the enclosure, a padlock, and two (2) keys. A fully installed door key lock is also available.</p>	FACTORY INSTALLATION YES	ORDERING Factory & Field Installation use Part Number when ordering Padlock 586/594: <i>EI0215-00</i> Padlock 5017/5018: <i>EI0215-01</i> Keylock 586/594: <i>EI0215-10</i> Keylock 5017/5018: <i>EI0215-11</i>
		AVAILABLE FOR FIELD INSTALLATION YES	

	<h3>Custom Paint</h3> <p>AT10.1 NEMA Type 1 enclosures feature an ANSI 61 gray epoxy powdercoat finish. Custom exterior and interior (e.g. semigloss white) colors are available in ANSI, PMS, and RAL color codes to meet specific requirements..</p>	FACTORY INSTALLATION YES	ORDERING <i>EI5064-00</i> SPECIFY WHEN PLACING ORDER USING YOUR SPECIFIC PAINT REQUIREMENTS
		AVAILABLE FOR FIELD INSTALLATION NO	NOT AVAILABLE FOR FIELD INSTALLATION

	<h3>NEMA Type 4 Cabinet</h3> <p>With this accessory, a fully assembled standard AT10.1 NEMA-1 vented enclosure is installed within another gasketed, sealed cabinet. The combined assembly meets the NEMA Type 4 (and therefore Type 12 and 13) enclosure specification. All ratings feature forced cooling, with user-supplied 120Vac for the fan.</p>	FACTORY INSTALLATION YES	ORDERING Factory Installation use Part Number when ordering STYLE 586: <i>EI0214-00</i> STYLE 594: <i>EI0214-00</i> STYLE 5017: <i>EI5036-00</i> STYLE 5018: <i>EI5037-00</i>
		AVAILABLE FOR FIELD INSTALLATION NO	NOT AVAILABLE FOR FIELD INSTALLATION

CUSTOMIZE YOUR AT10.1

OPTIONS THAT LET YOU DESIGN YOUR CHARGER EXACTLY HOW YOU NEED IT!



Rack Mounting Brackets

These accessories are provided when the AT10.1 enclosure is to be installed into a standard EIA relay rack. Smaller AT10.1 models may be installed into 19in racks, and all AT10.1s may be installed into 23in or 24in relay racks. All hardware is included for assembling the brackets to the AT10.1. Relay rack mounting hardware is user-supplied.

FACTORY
INSTALLATION

YES

AVAILABLE FOR
FIELD INSTALLATION

YES

ORDERING

Factory & Field Installation use
Part Number when ordering

Style-586 (19/23/24in): *EI0193-00*
Style-594 (23/24in): *EI0193-00*
Style-5017 (19in): *EI0193-01*
Style-5017 (23/24in): *EI0193-02*
Style-5018 (23/24in): *EI0193-03*



Floor Stand

This accessory is provided with smaller wall-mounted AT10.1 chargers when a vertical surface is not desired. The assembly mounts the AT10.1 approximately 44in / 1.12m from the floor. The kit features mounting brackets, assembly hardware to secure the AT10.1 to the brackets, and user instructions with a drilling pattern. Floor mounting anchor bolts are still user-supplied.

FACTORY
INSTALLATION

YES

AVAILABLE FOR
FIELD INSTALLATION

YES

ORDERING

Factory Installation use
Part Number when ordering

EI0192-00

Field Installation use Part Number

EI0192-00



NEMA Type 2 Drip Shield

Standard AT10.1 battery chargers are supplied in NEMA Type 1 vented enclosures. The optional drip shield prevents overhead water and small falling particles from entering the top vented panels, protecting internal equipment from damage. The combined standard enclosure and drip shield meets the NEMA Type 2 specification.

FACTORY
INSTALLATION

YES

AVAILABLE FOR
FIELD INSTALLATION

YES

ORDERING

Factory & Field Installation use
Part Number when ordering

STYLE 586: *EI0191-00*
STYLE 594: *EI0191-00*
STYLE 5017: *EI0191-01*
STYLE 5018: *EI0191-02*

SUPPLEMENTAL PRODUCT



Fan Control Contactor

Lead-acid batteries produce hydrogen gas. This small wall-mounted external accessory provides a relay contactor to activate a battery installation vent or exhaust fan. Available in 10A or 20A models, the accessory is factory-set to provide relay closure when the AT10.1 enters into Equalize mode.

FACTORY
INSTALLATION

NO

AVAILABLE FOR
FIELD INSTALLATION

YES

ORDERING

CAN BE ORDERED WITH CHARGER
BUT MUST BE FIELD INSTALLED

Field Installation use Part Number
10 Amp Rating: *EJ5017-0#*
20 Amp Rating: *EJ5017-1#*
Contact manufacturer for
specific part number

SUPPLEMENTAL PRODUCT



AT-DC Distribution Panel

This product augments AT10.1 with a customized dc distribution panel for user-specified loads. The AT-DC is configurable to various combinations of main and branch breakers. The AT-DC panel is optimally supplied from the factory, mounted to the AT10.1 and pre-wired to the charger's dc output terminals. For additional product details, including applicable 3rd party agency approvals, refer to the AT-DC literature (JF5032-00).

FACTORY
INSTALLATION

YES

AVAILABLE FOR
FIELD INSTALLATION

YES

ORDERING

Factory & Field Installation use
Part Number when ordering

EJ5110-##

Refer to document (JF5032-00)
for model specific part number.

AT10.1 SERIES SPECIFICATION CHART

Electronic File: [click chart for printable PDF](#)

	DC Output Rating		AC Input Ampere Rating <i>Based on maximum rms value of the input current delivered to the charger under all operating conditions within manufacturer's specifications</i>								Battery Charger AC Circuit Breaker Ampere Rating <i>(standard AIC breakers)</i>								
	Volts	Amps	120 Vac	208 Vac	220 Vac	240 Vac	380 Vac	416 Vac	480 Vac	600 Vac	120 Vac	208 Vac	220 Vac	240 Vac	380 Vac	416 Vac	480 Vac	600 Vac	
Float Adjust 11.0-14.5Vdc Equalize Adjust 11.7-15.5.0Vdc Extended Equalize to 16Vdc*	12Vdc GROUP 1	6	3	2	2	1	1	1	1	1	10	10	10	10	2	2	2	15	
		12	3	2	2	2	2	2	2	1	1	10	10	10	10	4	4	2	15
		16	4	2	3	2	2	2	2	1	1	10	10	10	10	4	4	2	15
		20	6	3	3	3	2	2	2	2	2	10	10	10	10	4	4	3	15
		25	7	4	4	4	3	2	2	2	2	10	10	10	10	5	5	4	15
	12Vdc GROUP 2	30	9	6	5	5	3	3	3	2	15	10	10	10	5	5	5	15	
		40	11	7	6	6	4	3	3	3	20	10	10	10	5	5	5	15	
		50	14	8	8	7	5	4	4	3	20	15	15	15	10	10	5	15	
		75	21	13	12	11	7	6	6	5	35	20	20	20	10	10	10	15	
		100	28	16	15	13	10	8	8	8	40	25	20	25	15	15	15	15	
Float Adjust 22.0-29.5Vdc Equalize Adjust 23.4-31.0Vdc Extended Equalize to 32Vdc*	24Vdc GROUP 1	6	5	3	3	3	2	1	1	1	10	10	10	10	3	3	3	15	
		12	8	5	4	4	3	2	2	1	10	10	10	10	4	4	3	15	
		16	9	6	5	5	4	3	3	2	15	15	15	15	6	6	4	15	
		20	11	7	6	6	5	4	4	3	15	15	15	15	8	8	6	15	
		25	14	9	8	7	6	4	4	4	20	20	20	20	8	8	6	15	
	24Vdc GROUP 2	30	16	8	8	8	5	5	4	4	20	10	10	10	10	10	5	15	
		40	20	12	12	11	8	7	6	5	25	15	15	15	10	10	10	15	
		50	26	15	15	14	8	8	7	6	35	20	20	20	10	10	10	15	
		75	42	26	23	22	14	13	11	10	70	35	30	35	20	20	15	15	
		100	51	25	24	22	14	12	11	11	80	35	30	35	25	25	20	15	
Float Adjust 44.0-58.0Vdc Equalize Adjust 46.8-59.0Vdc Extended Equalize to 61Vdc*	48Vdc GROUP 1	6	9	5	5	5	4	3	3	2	15	15	15	15	6	6	4	15	
		12	15	9	9	8	5	4	4	3	20	20	20	20	8	8	6	15	
		16	18	12	11	10	7	5	5	4	25	25	25	25	10	10	8	15	
		20	23	13	13	12	9	6	6	5	30	30	30	30	13	13	8	15	
		25	29	17	17	16	12	8	8	7	40	40	40	40	15	15	10	15	
	48Vdc GROUP 2	30	28	16	16	15	8	8	7	6	35	20	20	20	15	15	15	15	
		40	38	22	19	19	12	11	9	8	50	30	25	30	15	15	15	15	
		50	52	28	28	26	16	15	12	11	70	35	35	35	20	20	15	15	
		75	79	48	43	39	25	22	19	17	100	60	60	60	35	35	25	25	
		100	88	50	48	44	28	25	22	19	125	70	60	70	40	40	35	25	
Float Adjust 110.0-140.0Vdc Equalize Adjust 117.0-143.0Vdc Extended Equalize to 149Vdc*	130Vdc GROUP 1	6	15	9	8	8	5	5	4	4	20	20	20	20	8	8	8	15	
		12	32	18	16	15	10	9	8	7	40	40	40	40	13	13	13	15	
		16	34	20	18	17	11	10	9	8	50	50	50	50	13	13	13	15	
		20	40	24	23	23	15	14	12	11	60	60	60	60	20	20	20	15	
		25	50	30	28	27	18	16	14	12	70	70	70	70	25	25	20	15	
	130Vdc GROUP 2	30	75	44	42	40	23	22	20	16	100	60	60	60	35	35	25	20	
		40	100	59	57	53	35	32	28	17	125	80	80	80	60	60	35	30	
		50	N/A	72	68	63	40	36	32	28	N/A	100	100	100	50	50	40	35	
		75	N/A	100	83	81	52	47	40	36	N/A	125	125	125	70	70	50	50	

*Regulation at max. equalize voltages may not meet $\pm 0.25\%$

HOW TO SIZE YOUR CHARGER

(simplified formula)

$$\left(\frac{Ah \times 1.R}{t} \right) + L = \text{Continuous Charger Output Rating}$$

Ah=Ampere hours removed
 R= Recharge factor (1 = Pb) or (3 = NiCd)
 L= Additional standing load
 t= Recharge time in hours

Electronic File: click chart for printable PDF

DC Circuit Breaker Rating	Cabinet Style	Approx. Shipping Weights lbs.(kg)	Heat Loss Watts (BTU/hr)
10	586	83 (38)	31 (105)
20	586	87 (40)	58 (199)
25	586	92 (42)	77 (262)
30	586	118 (54)	95 (326)
40	586	100 (46)	119 (404)
50	5017	184 (84)	142 (483)
60	5017	189 (86)	188 (641)
80	5017	194 (88)	234 (798)
100	5018	199 (91)	350 (1192)
150	5018	225 (103)	465 (1587)
10	586	99 (45)	40 (136)
20	586	109 (50)	75 (255)
25	586	115 (53)	98 (334)
30	586	119 (54)	121 (413)
40	586	136 (62)	150 (512)
50	5017	259 (118)	179 (612)
60	5017	267 (122)	237 (810)
80	5017	342 (156)	295 (1008)
100	5018	355 (162)	441 (1503)
150	5018	360 (164)	586 (1999)
10	586	105 (48)	60 (203)
20	586	120 (55)	107 (365)
25	594	155 (71)	139 (473)
30	594	170 (78)	170 (581)
40	594	180 (82)	210 (717)
50	5017	217 (99)	250 (852)
60	5017	225 (103)	329 (1122)
80	5017	250 (114)	408 (1392)
100	5018	433 (197)	606 (2068)
150	5018	450 (205)	804 (2743)
10	586	130 (59)	99 (337)
20	594	155 (71)	167 (571)
25	594	215 (98)	213 (727)
30	594	225 (103)	259 (883)
40	594	265 (120)	316 (1078)
50	5017	285 (130)	373 (1273)
60	5018	340 (155)	484 (1664)
80	5018	375 (171)	602 (2054)
100	5018	482 (219)	888 (3030)



Cabinet Style 586



Cabinet Style 594



Cabinet Style 5017



Cabinet Style 5018

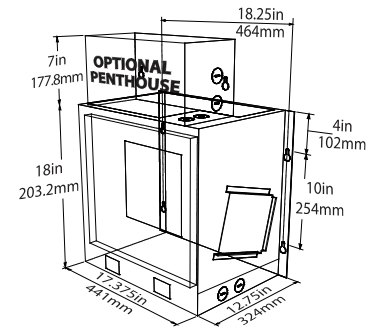
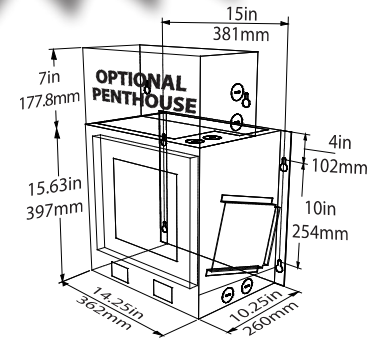

GROUP 1

6-25Adc

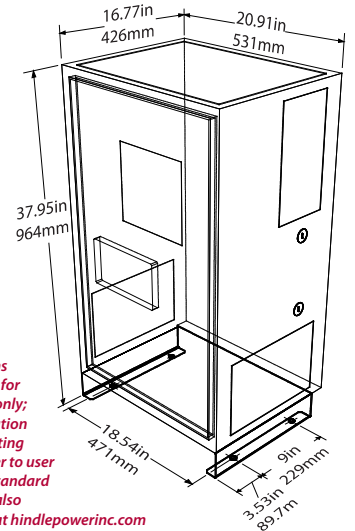
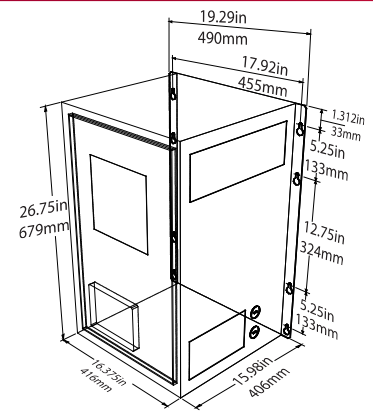

GROUP 2

30-100Adc

*NOTE:
 Dimensions shown are for reference only; for installation and mounting please refer to user manual. Standard drawings also available at hindlepowerinc.com

GROUP 1

(6-25 Adc)

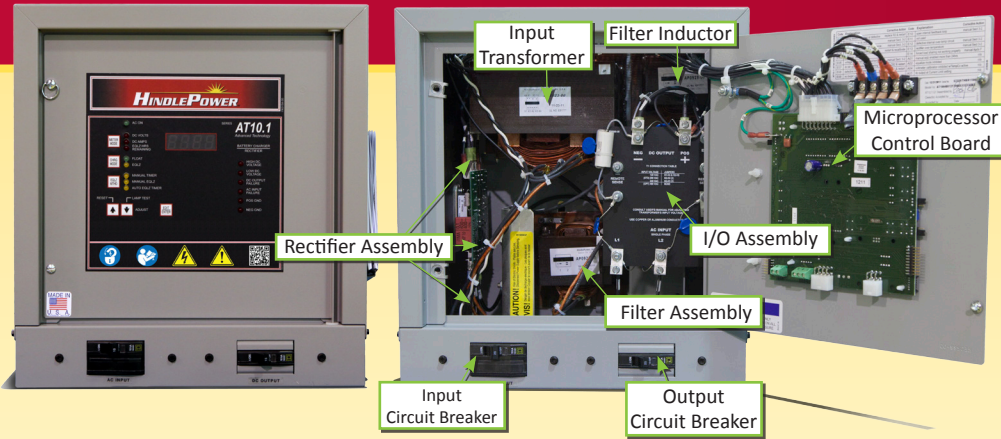

Circuit Breaker AC & DC Ratings

STANDARD

Input: 10kAIC - 240Vac
10kAIC - 480Vac
Output: 10kAIC - 125Vdc*

MEDIUM

Input: 25kAIC - 240Vac
18kAIC - 480Vac
18kAIC - 600Vac
Output: 10kAIC - 250Vdc

HIGH

Input: 65kAIC - 240Vac
25kAIC - 480Vac
18kAIC - 600Vac
Output: 20kAIC - 250Vdc

*For chargers 16Adc and larger; consult factory for other ratings.

GROUP 1 (6-25 Adc) - SPECIFICATION TABLE

	A	B			C			D	E			F	G			H	J	K	L
SAMPLE	AT10	0	1	2	0	0	6	E	2	4	0	S	A	U	X	G	L	X	X
YOUR CODE	AT10																		

	DESCRIPTION	CODE	FEATURE		DESCRIPTION	CODE	FEATURE
A		AT10	AT10 SERIES	F	Circuit Breaker Rating	S	Standard AIC
B	Nominal DC Output Voltage	012	12Vdc			M	Medium AIC
		024	24Vdc			H	High AIC
		048	48Vdc	G	AUX	Installed	
		130	130Vdc		XXX	Not Supplied	
C	Nominal DC Output Current	006	6Adc	H	Copper Ground Bus	G	Installed
		012	12Adc		X	Not Supplied	
		016	16Adc	J	AC Lightning Arrestor	L	Installed
		020	20Adc		X	Not Supplied	
		025	25Adc	K	Fungus Proofing	F	Applied
D	DC Output Filtering	U	Unfiltered		X	Not Supplied	
		F	Filtered	L	Static Proofing	S	Applied
		E	Batt. Eliminator		X	Not Supplied	
E	AC Input Voltage	120	120V 60Hz	This ordering code is unique for AT10.1chargers rated 6-25A output.			
		208	208V 60Hz				
		240	240V 60Hz				
		480	480V 60Hz				
		220	220V 50/60Hz				
		380	380V 50/60Hz				
		416	416V 50/60Hz				
		600	550-600V 60Hz				

GROUP 2

(30-100 Adc)

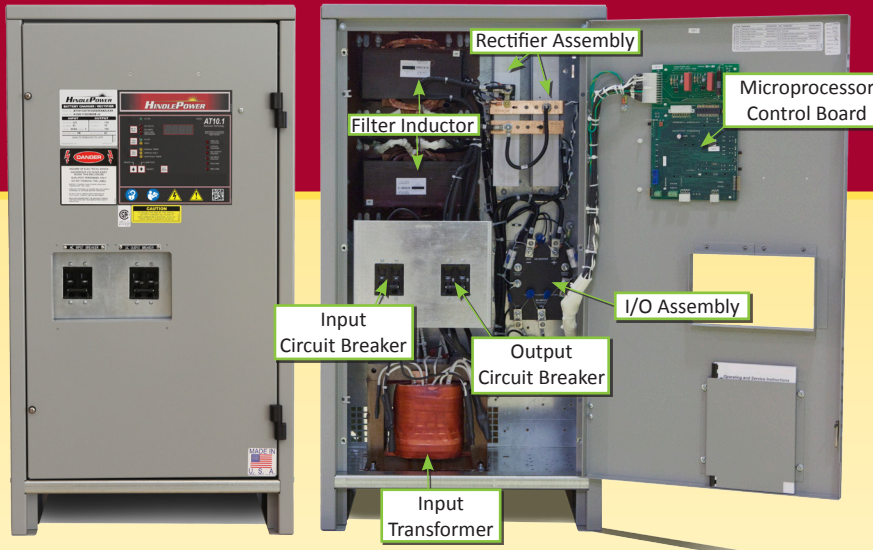

Circuit Breaker AC & DC Ratings

STANDARD
Input: 5kAIC - 120/208/240/480Vac
Output: 5kAIC - 125Vdc

MEDIUM
Input: 25kAIC - 120/208/240/480Vac
18kAIC - 600Vac
Output: 10kAIC - 250Vdc

HIGH
Input: 65kAIC - 120/208/240/480Vac
25kAIC - 600Vac
Output: 20kAIC - 250Vdc

GROUP 2 (30-100 Adc)- SPECIFICATION TABLE

A	B			C			D	E			F	G	H	J	K	L	M	N	P
SAMPLE AT10	1	3	0	0	5	0	F	4	8	0	S	F	S	X	A	X	X	X	X

YOUR CODE AT10																			
----------------	--	--	--	--	--	--	--	--	--	--	--	--	--	--	--	--	--	--	--

	DESCRIPTION	CODE	FEATURE		DESCRIPTION	CODE	FEATURE		
A		AT10	AT10 SERIES						
B	Nominal DC Output Voltage	012	12Vdc	F	AC Input Circuit Breaker Rating	S	Standard AIC		
		024	24Vdc			M	Medium AIC		
		048	48Vdc			H	High AIC		
		130	130Vdc			0	No Breaker		
C	Nominal DC Output Current	030	30A dc	G	AC Input Fuses	F	Installed		
		040	40A dc			X	Not Supplied		
		050	50A dc			H	DC Output Circuit Breaker Rating	S	Standard AIC
		075	75A dc					M	Medium AIC
100	100A dc	H	High AIC	0	No Breaker				
D	DC Output Filtering	U	Unfiltered	J	DC Output Fuses	F	Installed		
		F	Filtered			X	Not Supplied		
		E	Batt. Eliminator			K	Auxiliary Alarm Relay Board	A	Installed
120	120V 60Hz	X	Not Supplied						
E	AC Input Voltage* <small>*Group 2 inputs cannot be retapped in field</small>	208	208V 60Hz	L	Copper Ground Bus	G	Installed		
		240	240V 60Hz			X	Not Supplied		
		480	480V 60Hz	M	AC Lightning Arrestor	L	Installed		
		220	220V 50/60Hz			X	Not Supplied		
		380	380V 50/60Hz	N	Fungus Proofing	F	Applied		
		416	416V 50/60Hz			X	Not Supplied		
		600	550-600V 60Hz	P	Static Proofing	S	Applied		
X	Not Supplied								

This ordering code is unique for AT10.1chargers rated 30-100A output.